

BODY ELECTRICAL SYSTEM

FEATURES	15- 2
COMBINATION METER	15- 3
CLUSTER SWITCHES	15- 3
LOCATION OF SWITCHES	15- 6
LOCATION OF RELAYS AND UNITS	15- 7
NEW AUDIO SYSTEMS	15- 8
HEATER SYSTEM	15-10

FEATURES

1. The combination meter & instrument panel has a new design.
2. A cluster switch has been newly provided.
3. A fuel low-level warning light has been provided.
4. The heater blower control switch has been changed from 3 positions to 4 positions.
5. A new audio system has been equipped.
6. A logical mode control system has been provided for the heater and air-conditioner.

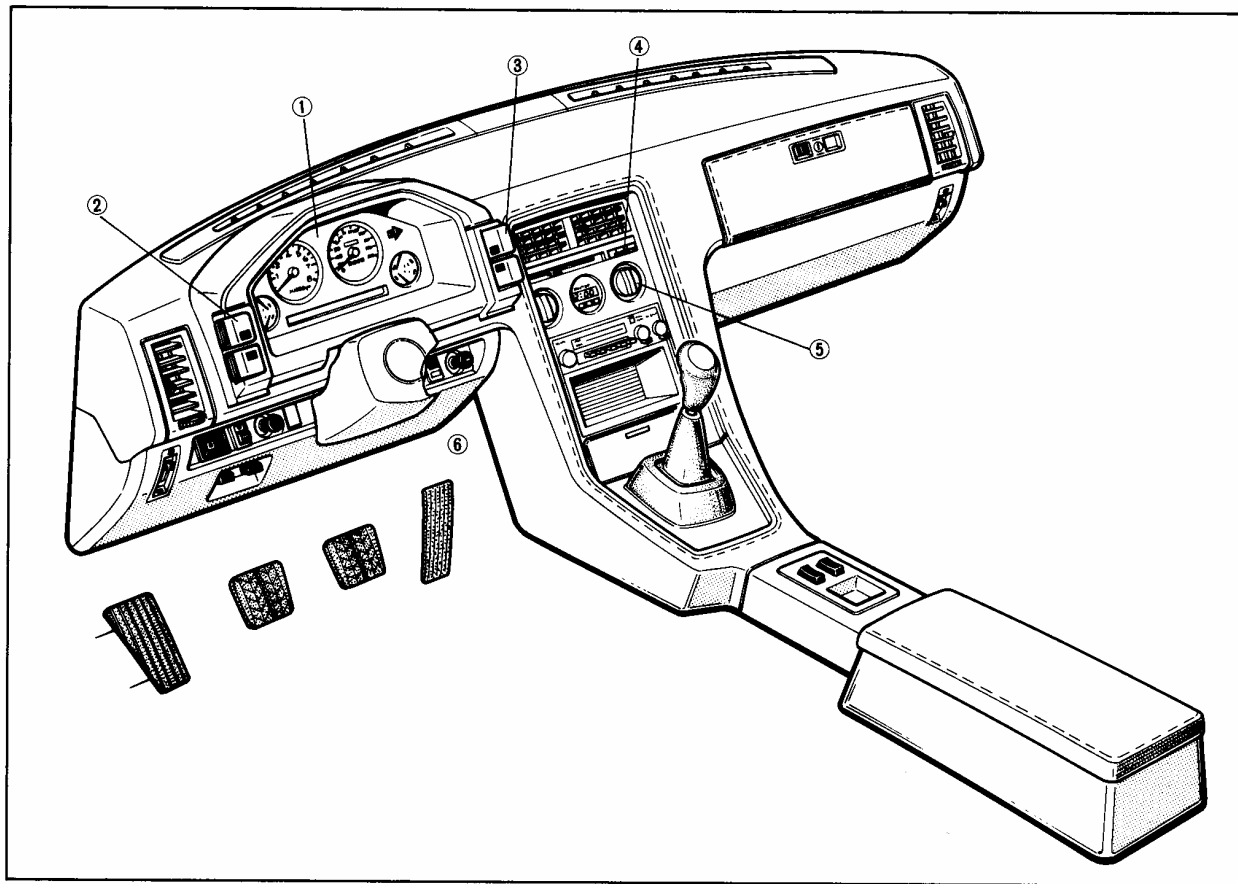

- | | |
|--------------------------|---|
| 1 Combination meter | 4 Air-conditioner switch & recirc. switch |
| 2 Cluster switch (left) | 5 Temperature-control switch |
| 3 Cluster switch (right) | 6 Blower-control switch |

COMBINATION METER

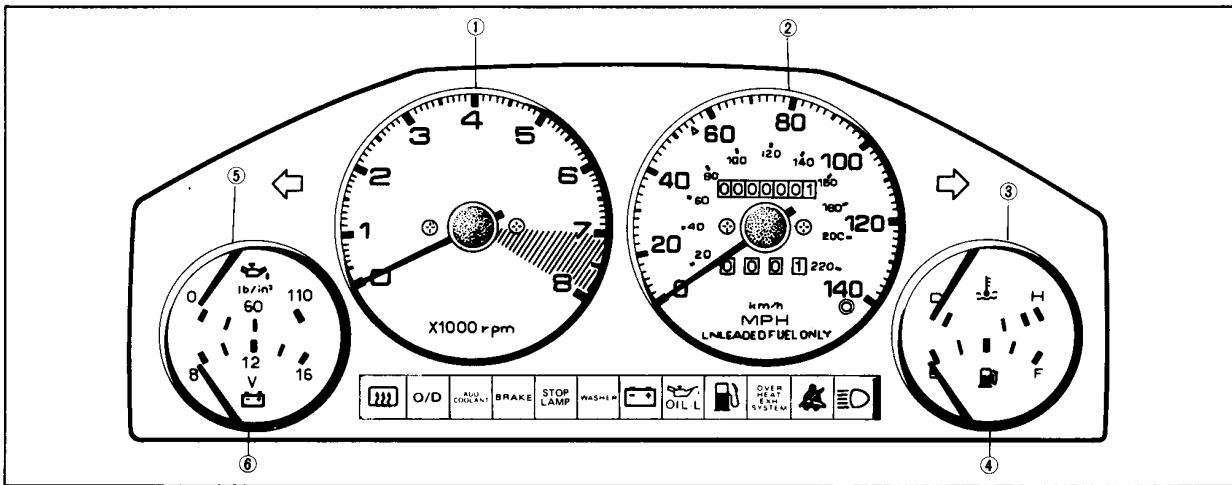

- | | |
|---------------------------|----------------------|
| 1 Tachometer | 4 Fuel gauge |
| 2 Speedometer | 5 Oil pressure gauge |
| 3 Water temperature gauge | 6 Voltmeter |

CLUSTER SWITCHES

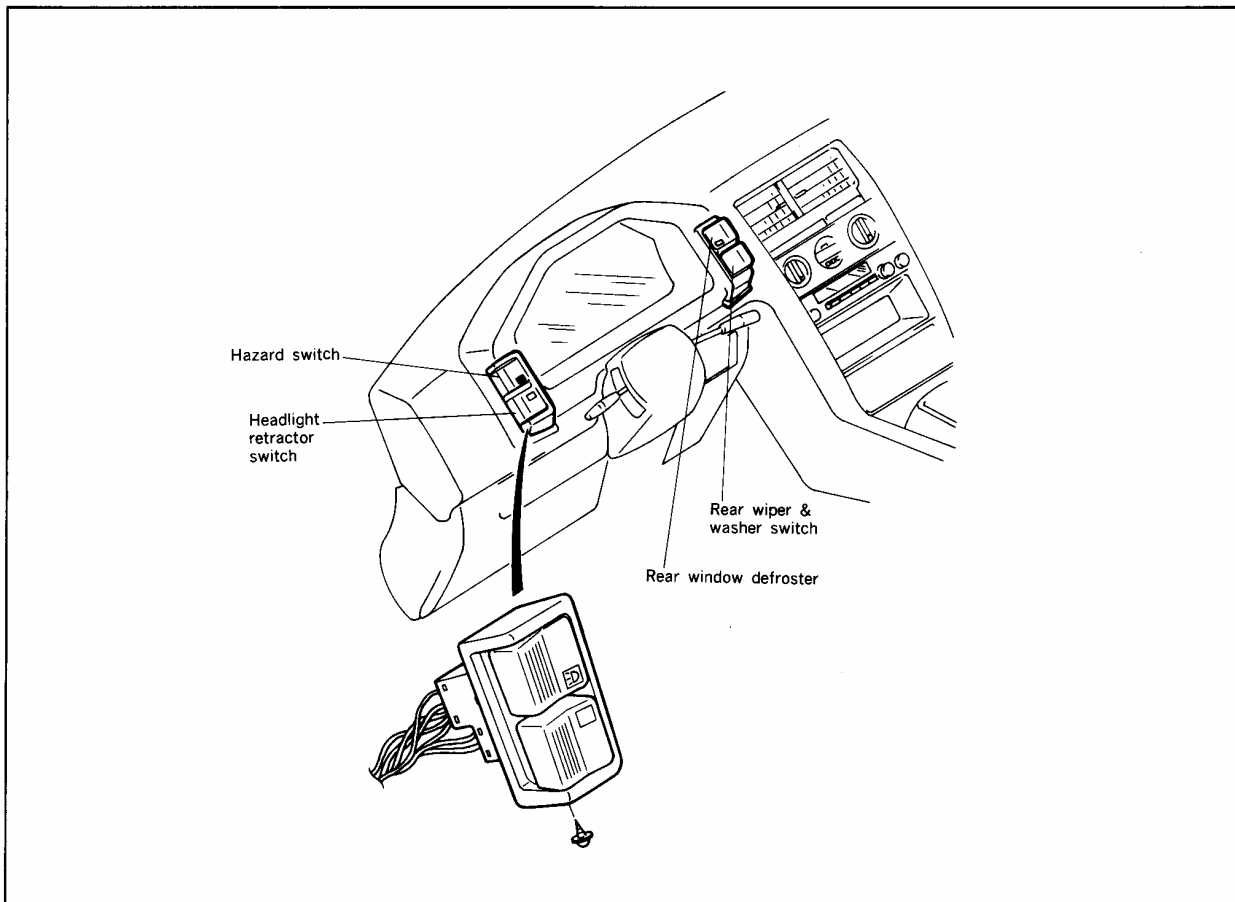

CIRCUIT DIAGRAM OF LEFT CLUSTER SWITCH

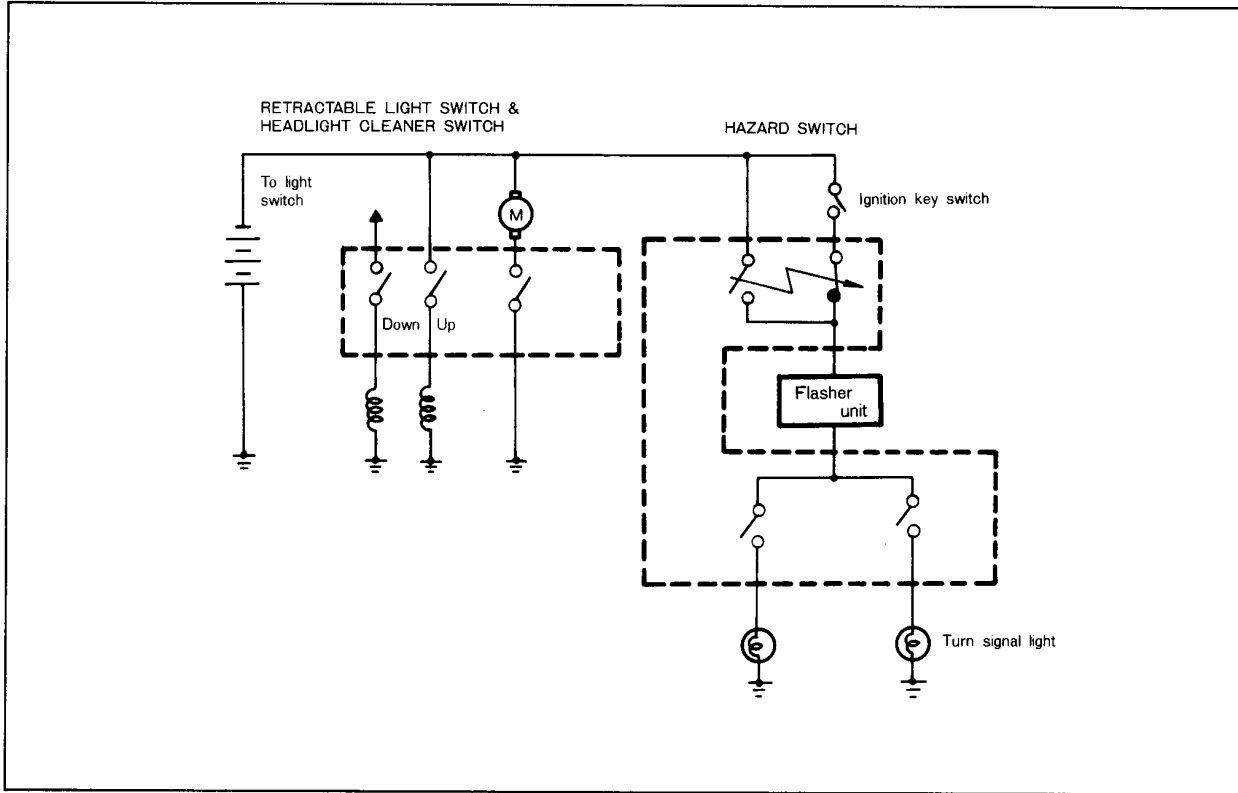

CIRCUIT DIAGRAM OF RIGHT CLUSTER SWITCH

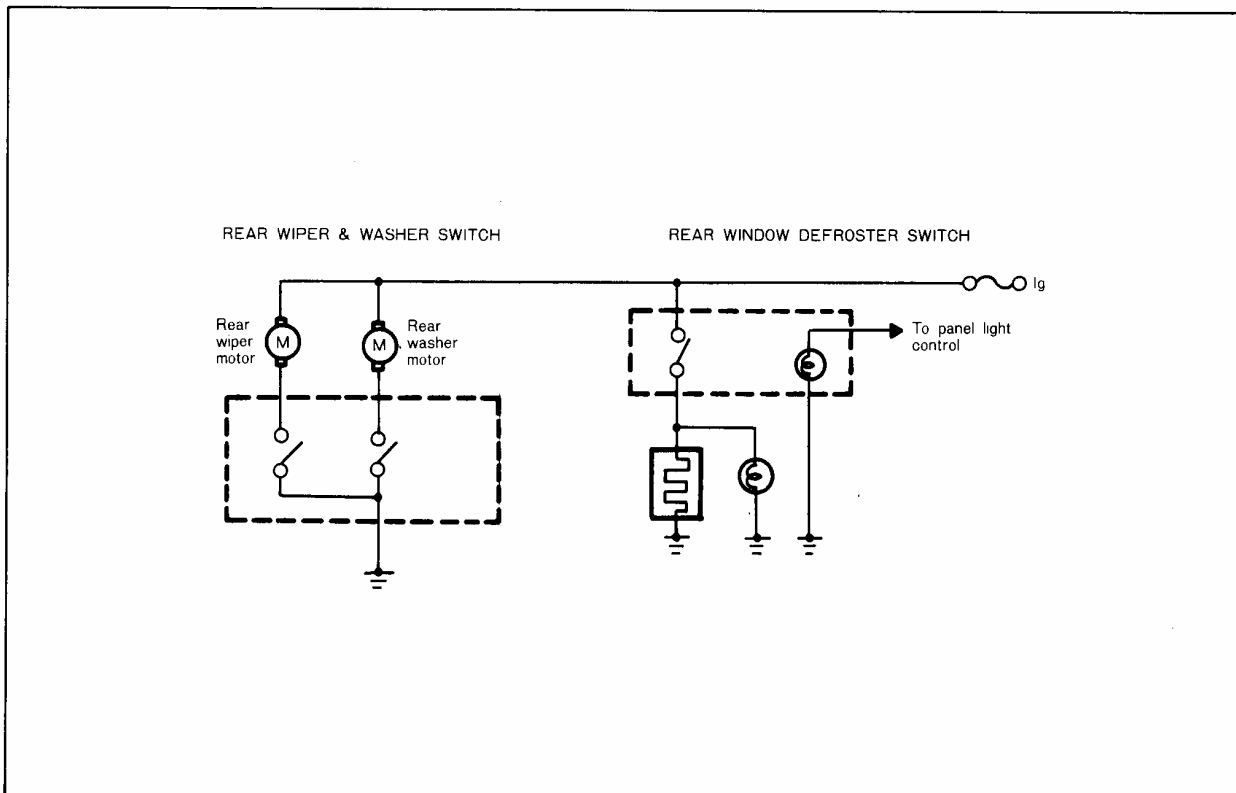

Removal and disassembly of the combination meter

When removing the combination meter, the cluster switches and meter hood must first be removed.

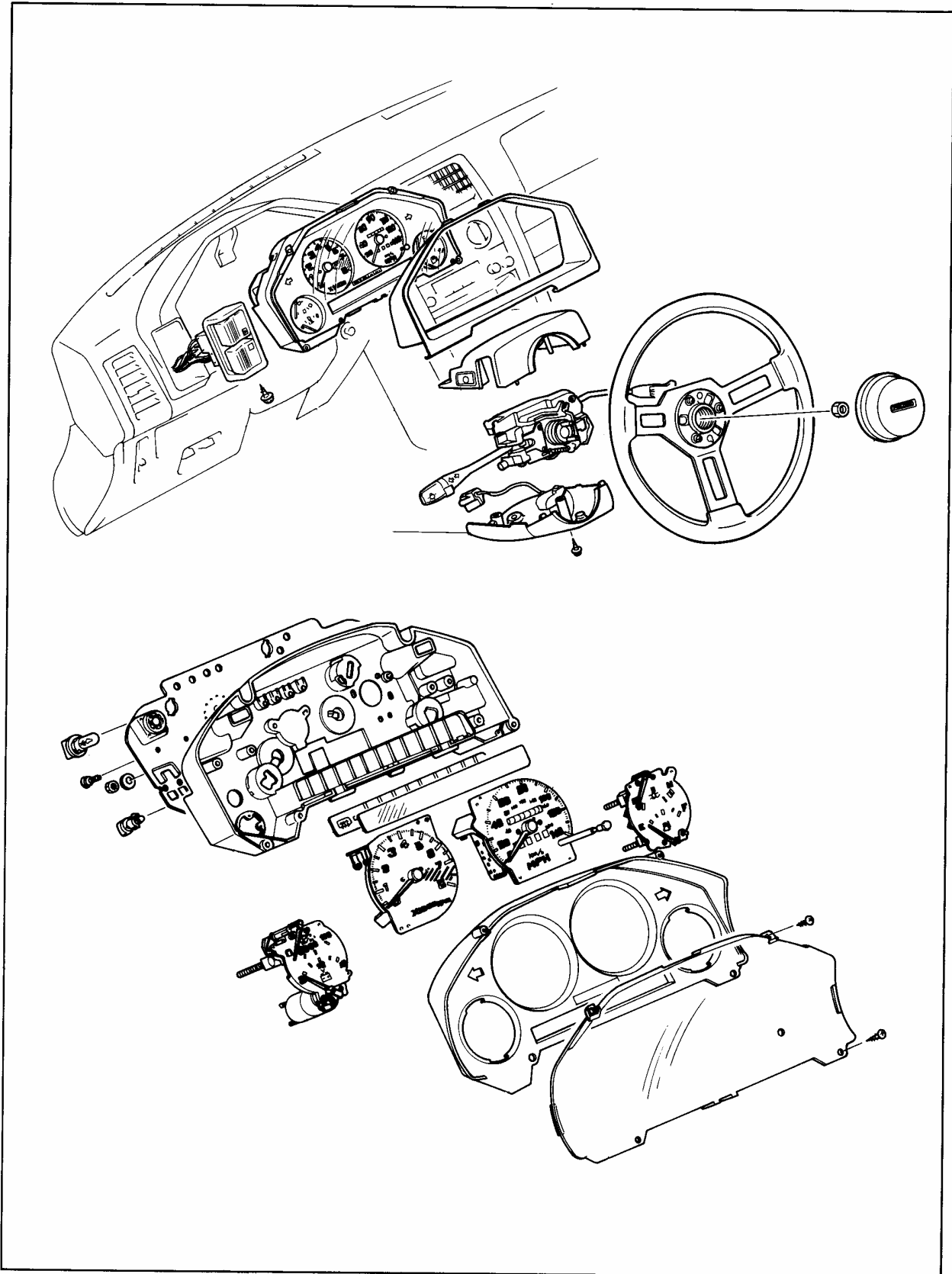

LOCATION OF SWITCHES

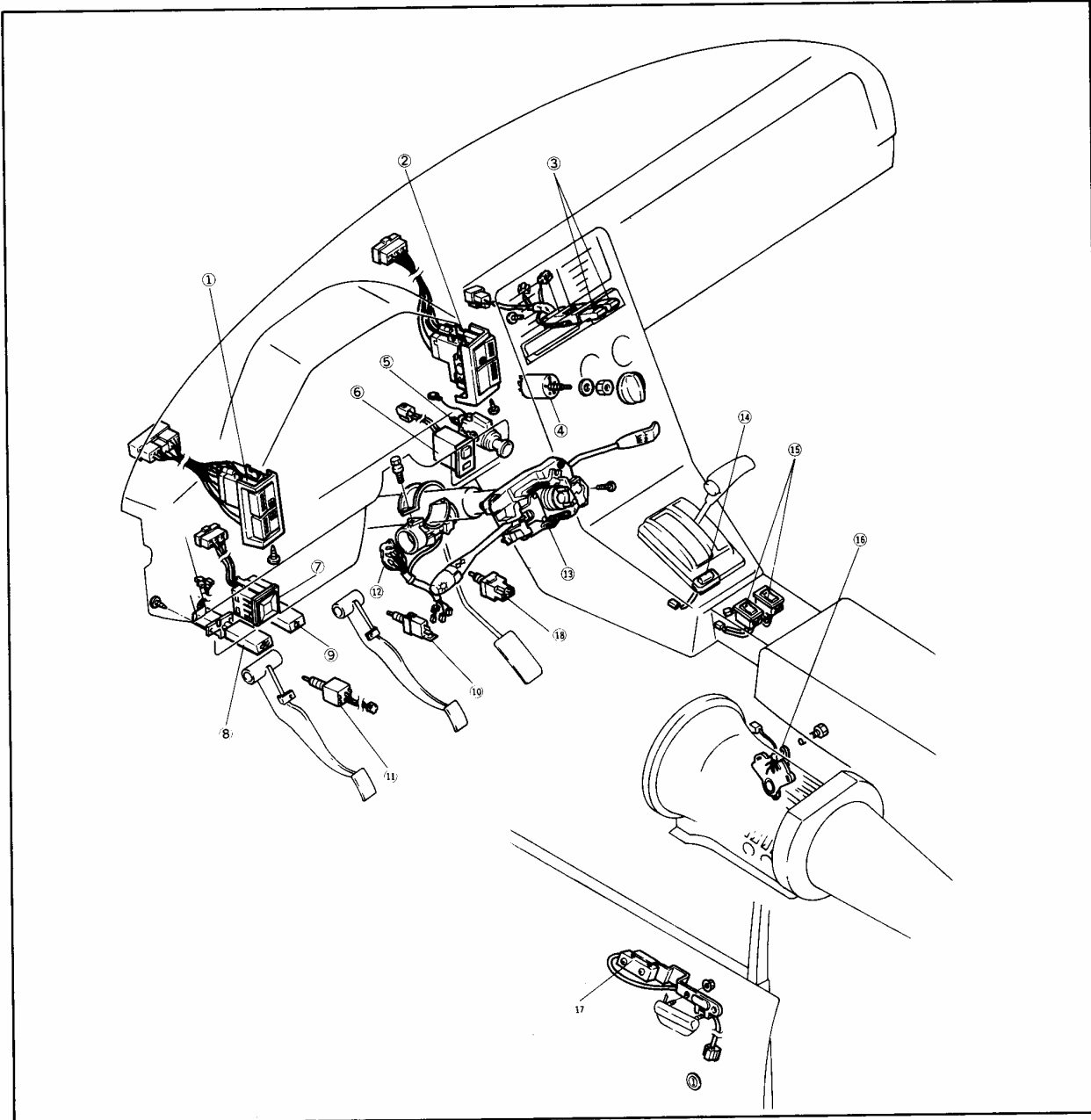

- | | |
|--|---|
| 1 Cluster switch (hazard, retractable light & headlight cleaner) | 11 Clutch switch |
| 2 Cluster switch (rear defroster, rear wiper & washer) | 12 Ignition key switch |
| 3 Air con. & mode-control switch | 13 Combination switch (light, turn, wiper & washer, horn) |
| 4 Blower switch | 14 Overdrive switch (for 4AT vehicles) |
| 5 Cigarette lighter | 15 Power-window switch |
| 6 Cruise-control main switch | 16 Inhibitor switch |
| 7 Remove-control mirror switch | 17 Outer door handle switch |
| 8 Remote glass hatchback opener switch | 18 Kick-down switch |
| 9 Remote full door opener switch | |
| 10 Stop light switch | |

LOCATION OF RELAYS AND UNITS

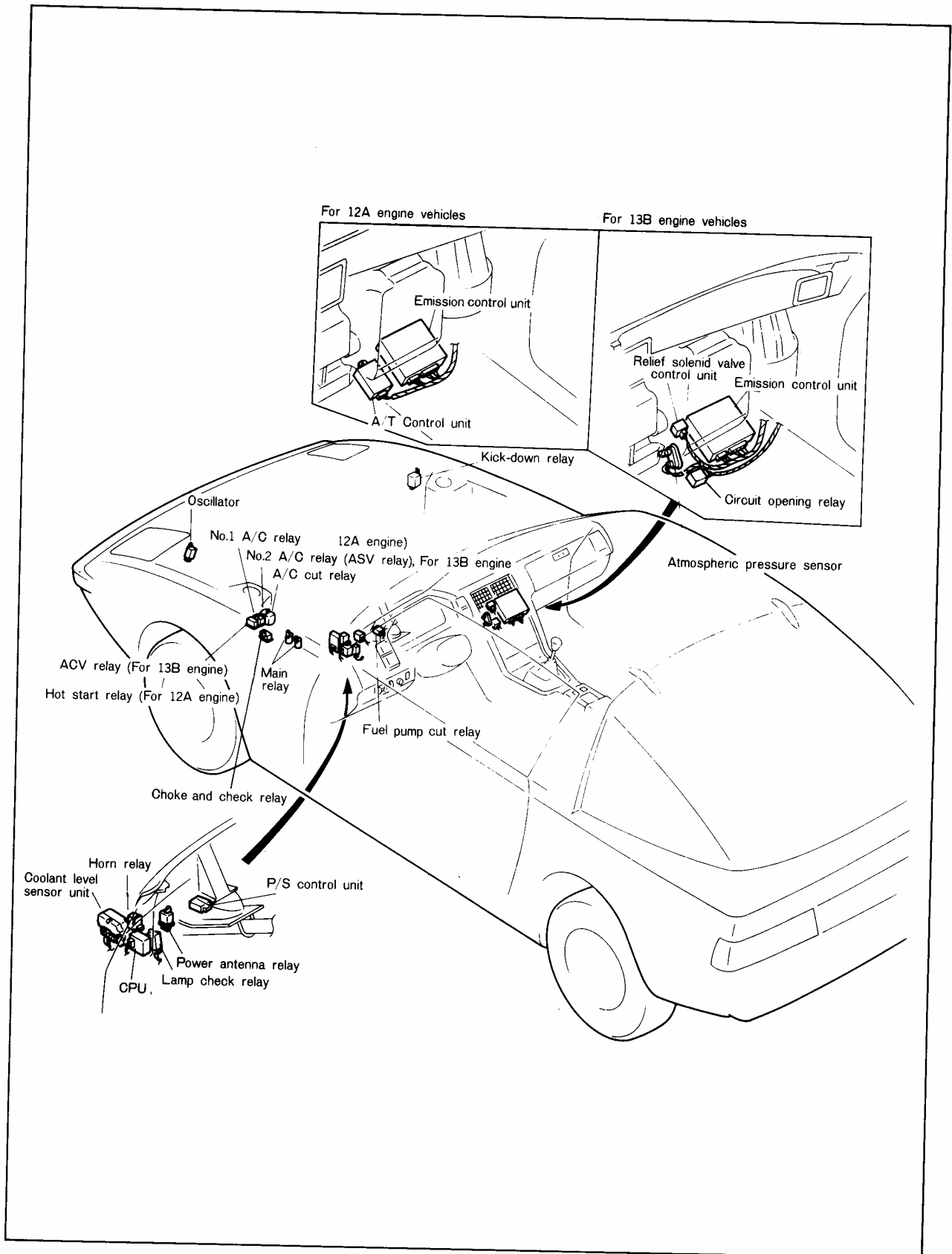

NEW AUDIO SYSTEM

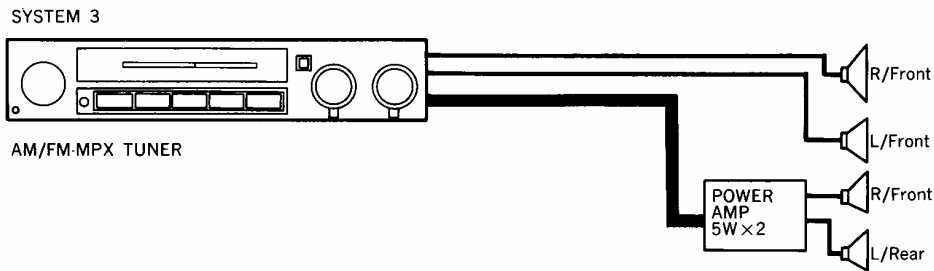
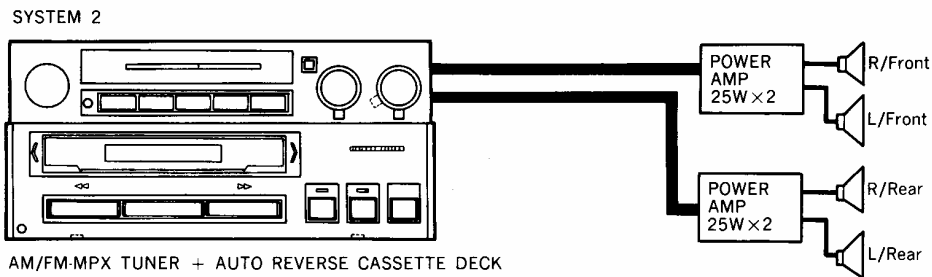
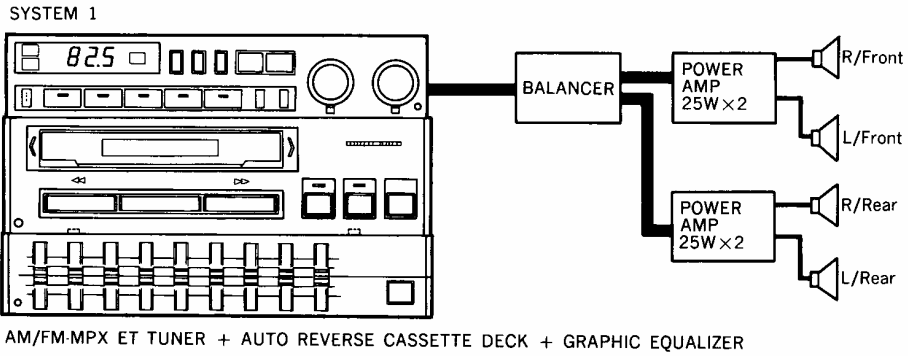

AUDIO SYSTEM STRUCTURAL VIEW

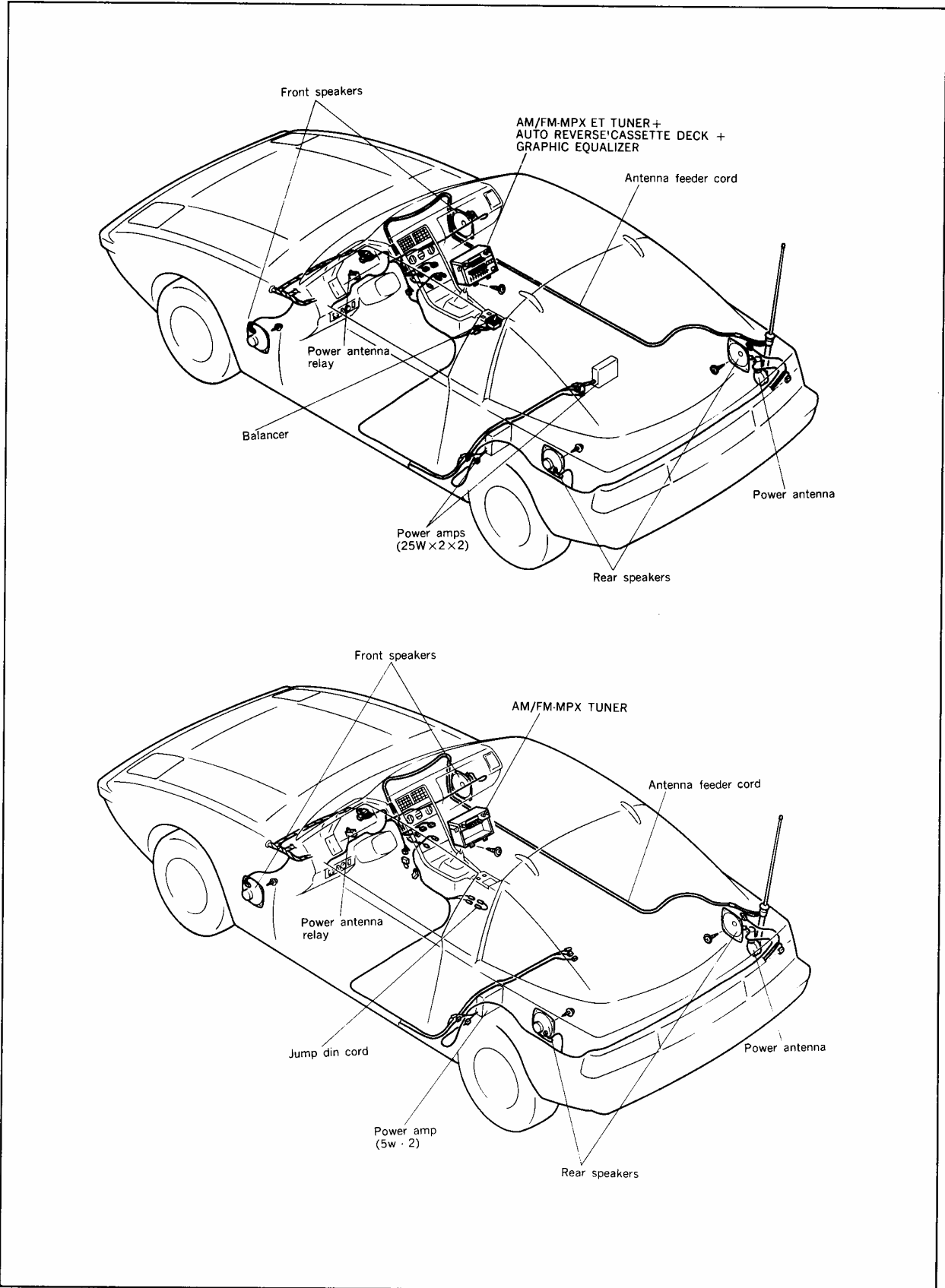

HEATER SYSTEM

FEATURES

1. The FRESH/REC switching is done by a motor for all vehicles (all grades).
2. The switching of mode is done, depending upon the model grade, either by motor or, as in the past, manually by wire.
3. Operation of the temperature control wire is done by the round knob.
4. The air-flow control of the blower is changed from 3 steps to 4 steps.

LEVER CONTROL TYPE

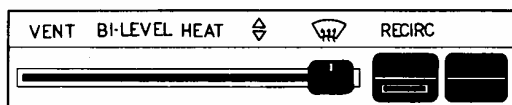

LOGICAL CONTROL TYPE

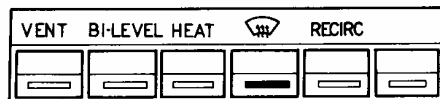

MODE-CONTROL MOTOR

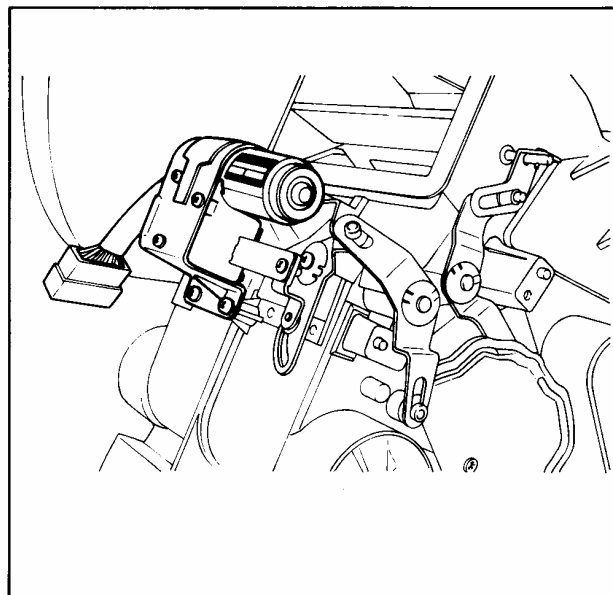

FRESH-REC CONTROL MOTOR

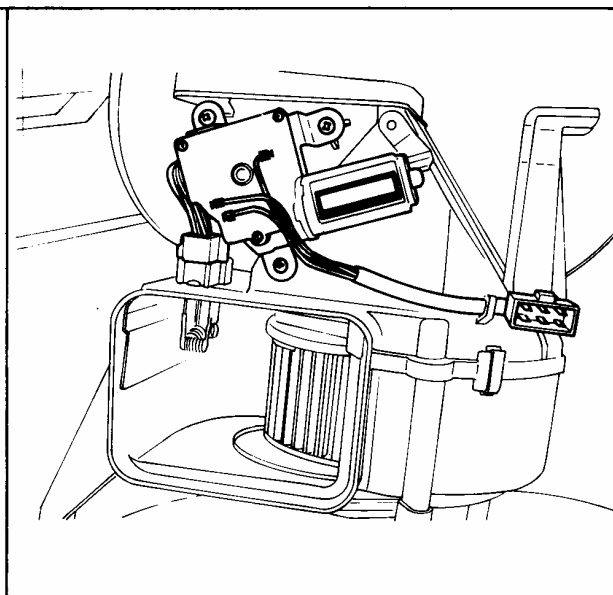

TEMPERATURE CONTROL

The temperature is controlled by a mechanism by which the control cable is pushed and pulled by turning the knob.

When the knob is turned as shown in the figure, the rack is moved either to the left or to the right by the gear on the knob shaft. This movement of the rack causes the lever interlocked with the rack to move. The temperature-control cable is connected to the opposite end of the lever, and the inner cable is pushed and pulled by the lever.

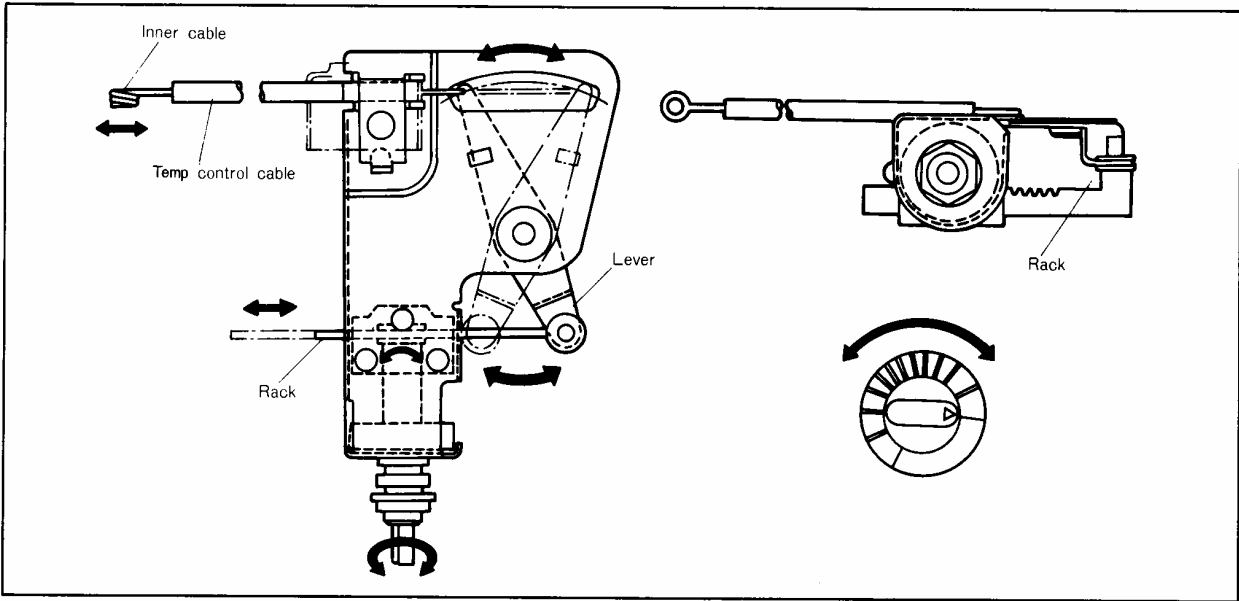

FRESH-RECIRC. CONTROL MOTOR

The fresh-recirc. control motor is installed next to the blower unit. The selector door is opened and closed by the motor's power.

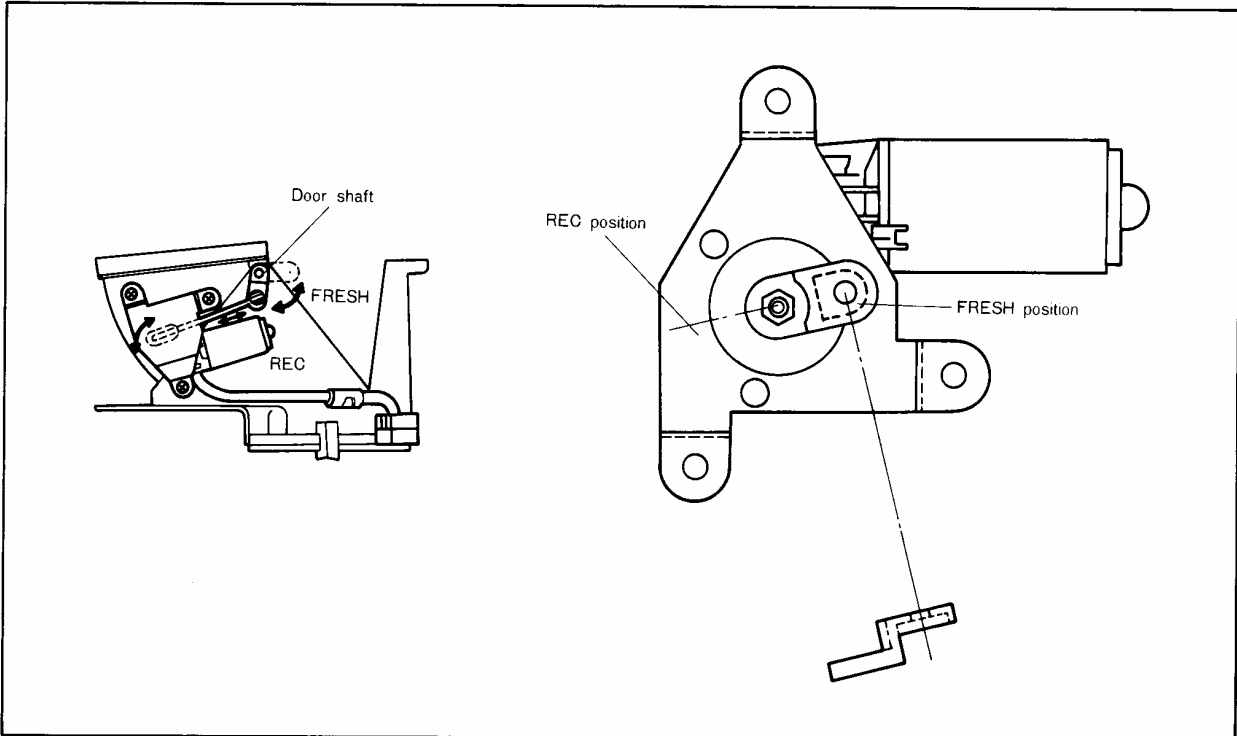

MODE-CONTROL MOTOR

When the mode-control button is pressed, the motor's rack moves, as shown in the figure, to each position respectively. The rack pushes and pulls the mode-control link to select each mode.

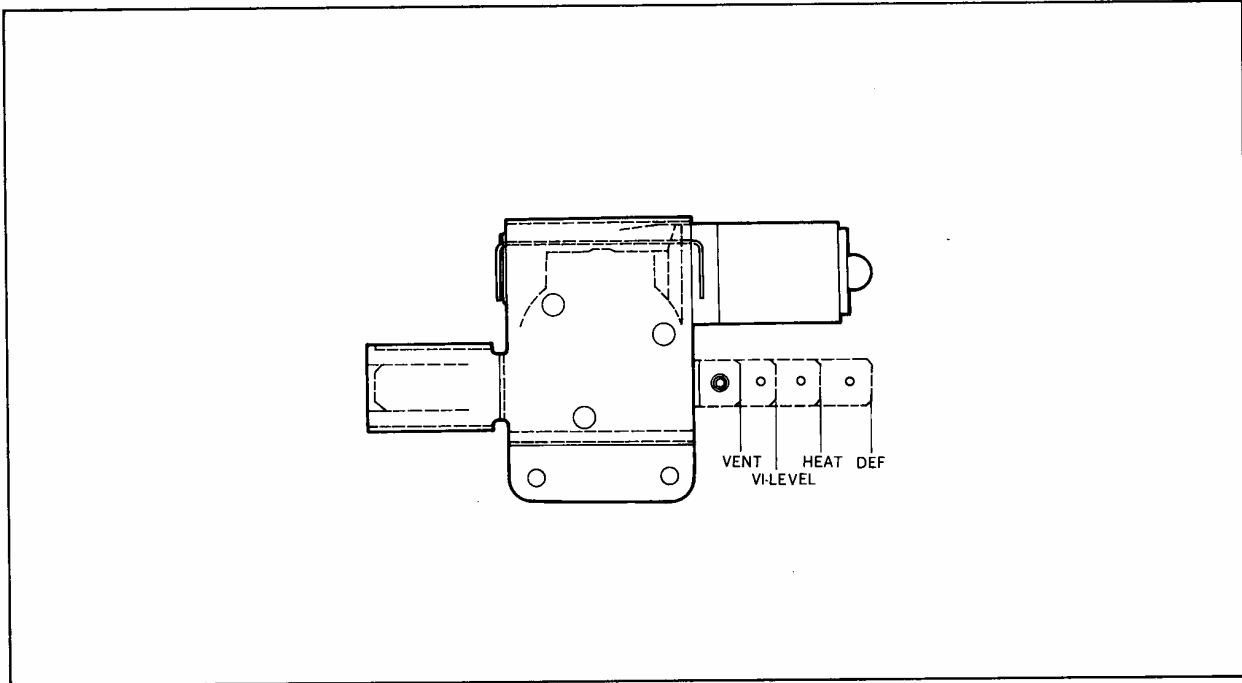

MODE-CONTROL SWITCHES

The mode-control switches, which are located together with the air-conditioner switch and recirculation switch, can be used for one-touch control of air conditioning.

The air-conditioner switch and recirculation switch are switched ON when pressed once, and are switched OFF when pressed once again. When ON, the indicator light will illuminate.

The mode-control switches are switched ON when pressed once, and will not be switched OFF unless a different switch is pressed. In other words, one of the switches is always ON. The illumination of the indicator light indicates that the switch is ON. There is, in addition, an illumination light for nighttime lighting.

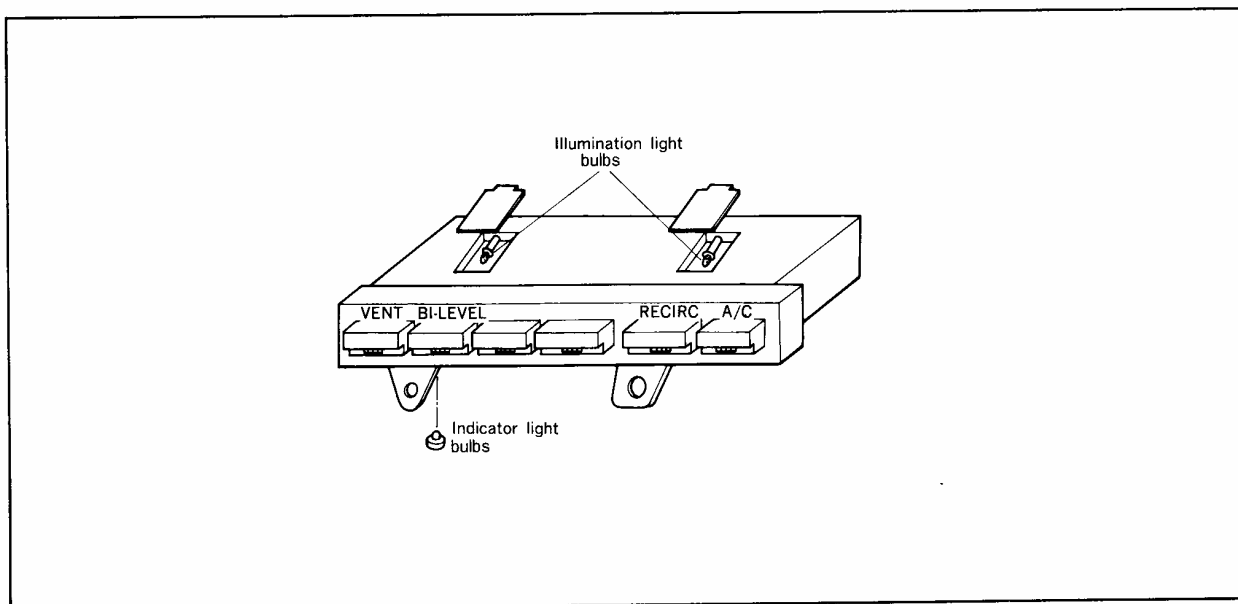

Circuit diagram (lever control type)

Indicates ON condition of RECIRC. switch.

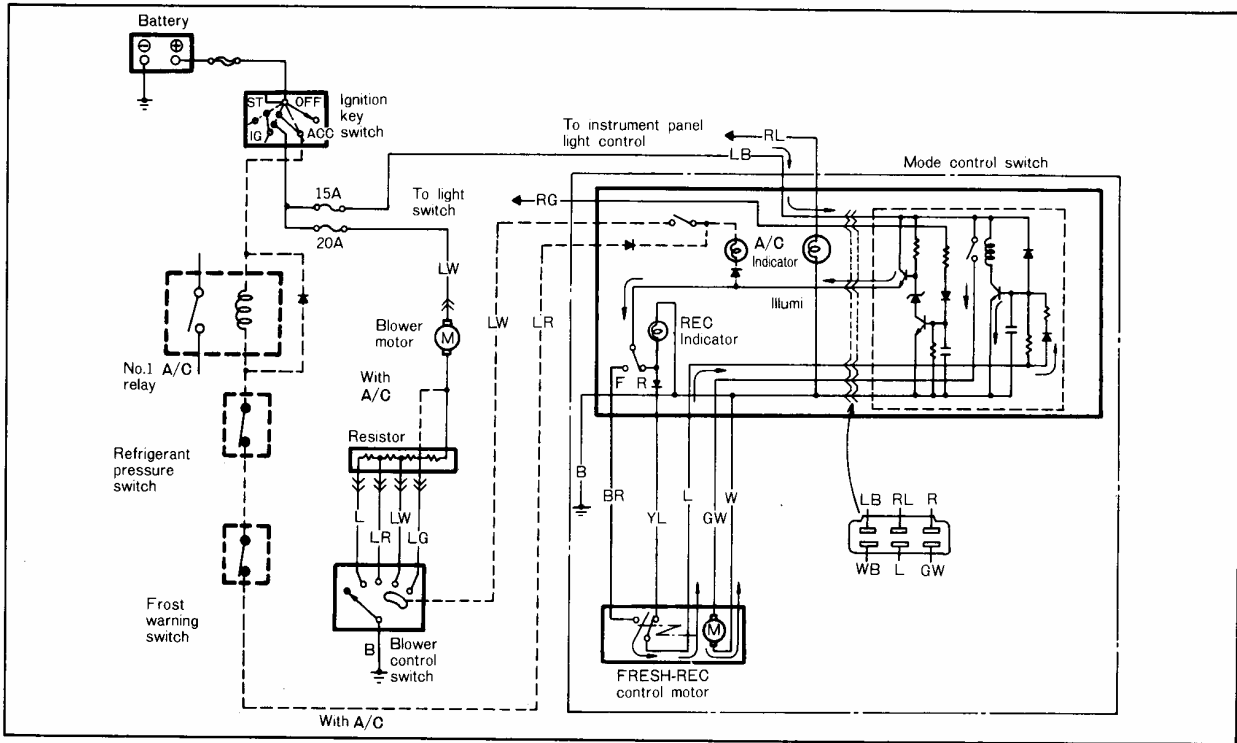

Logical control type

Indicates ON condition of HEAT switch.

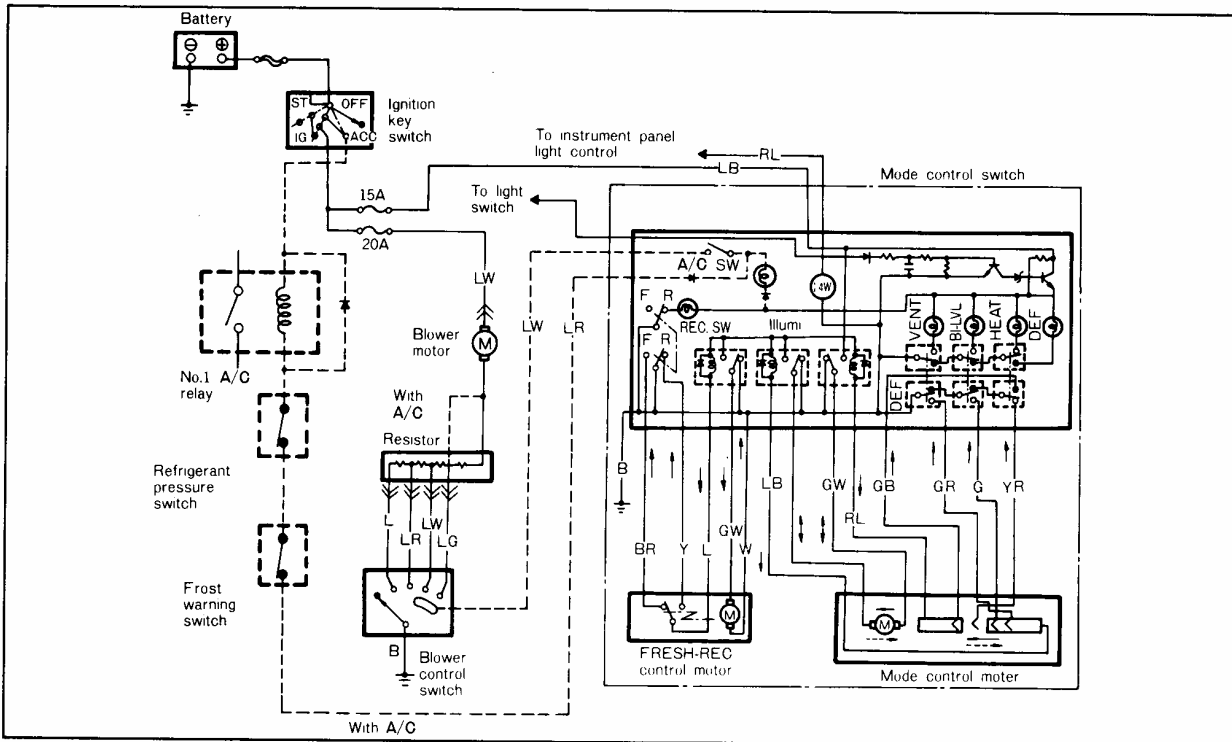

Logical control type operation examples

Operation when the VENT switch is pressed while the HEAT switch is ON

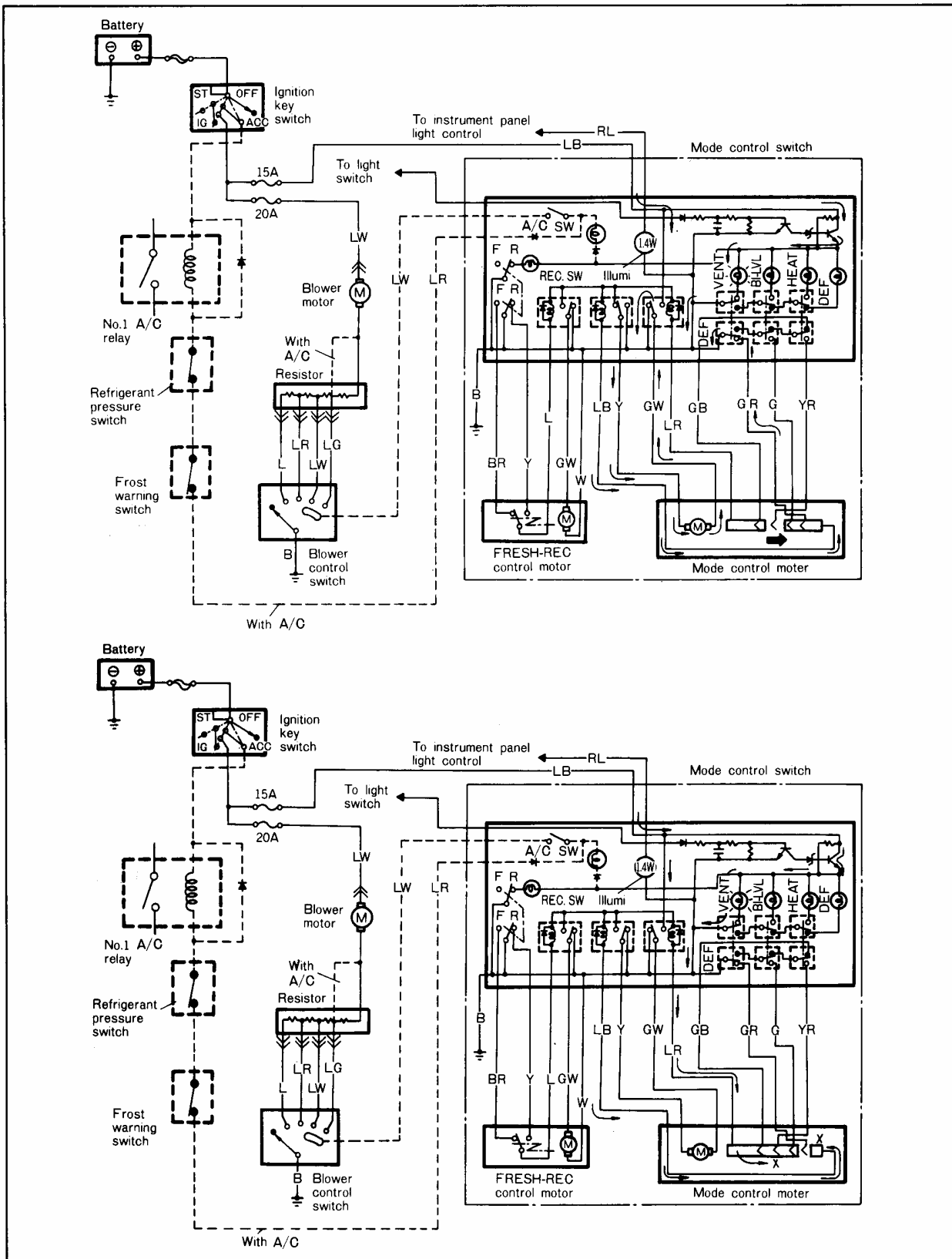

Operation when the DEF switch is pressed while the VENT switch is ON

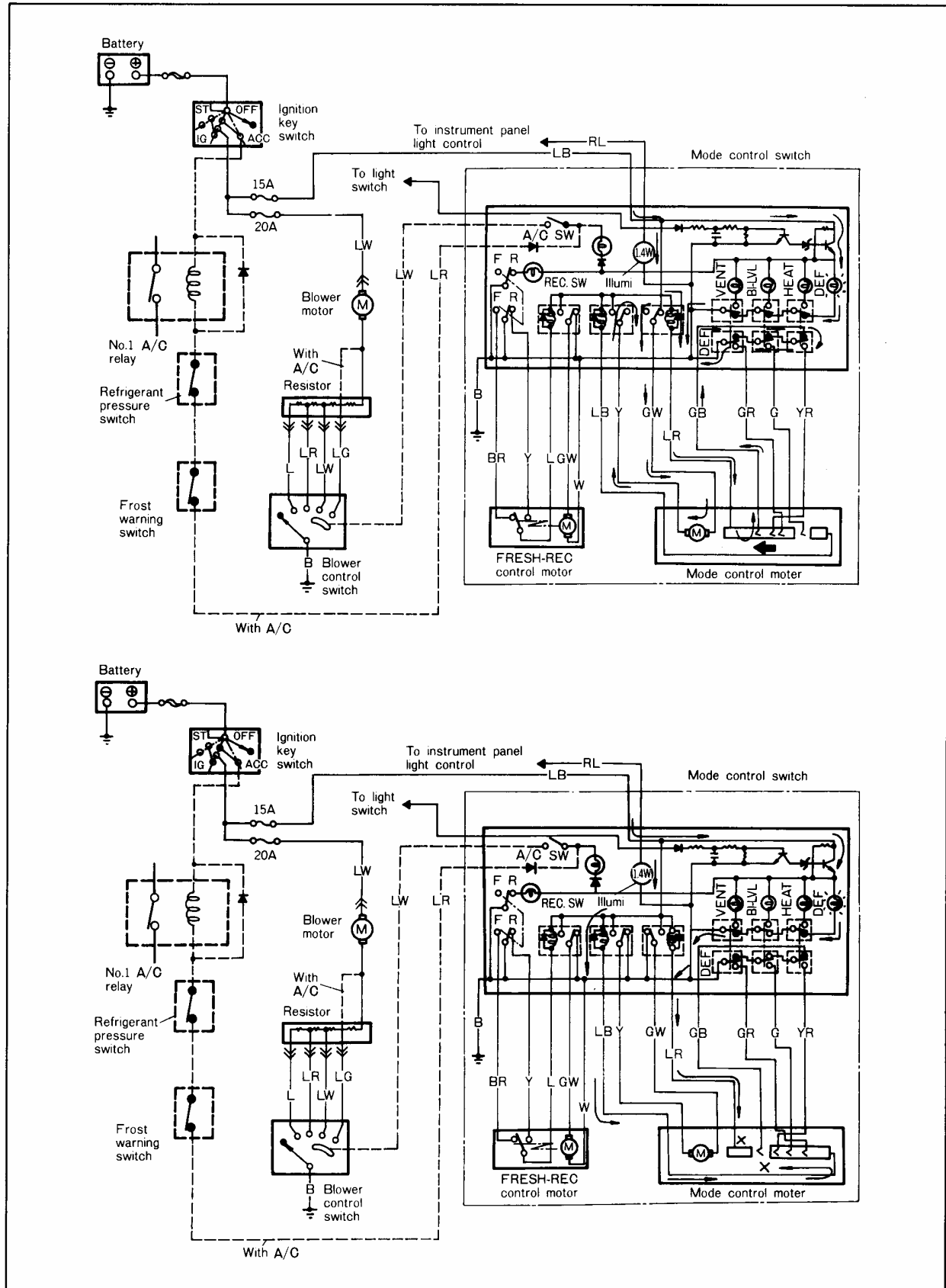

Operation when the BI-LEVEL switch is pressed while the DEF switch is ON

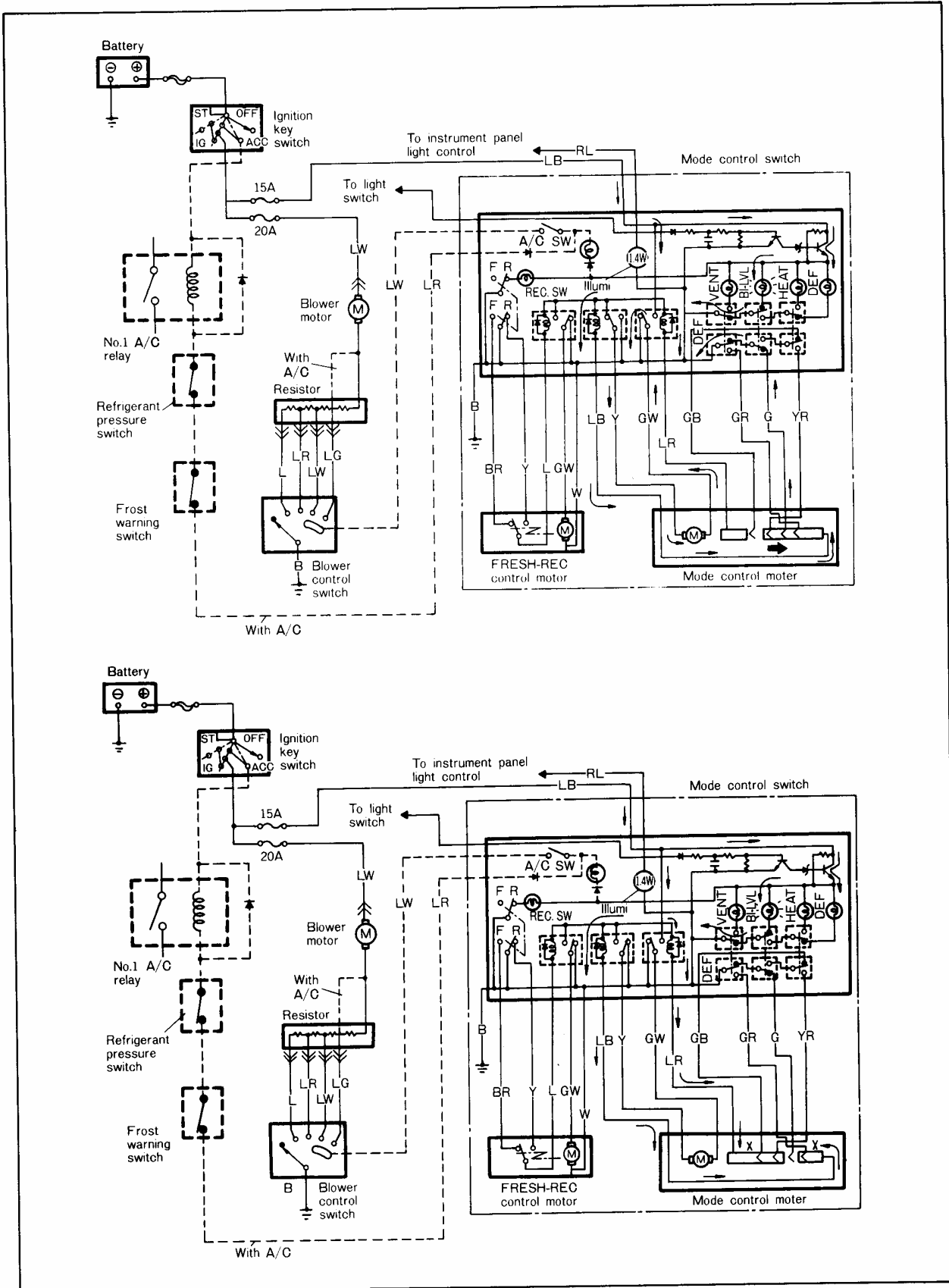

Operation when the RECIRC. switch is pressed

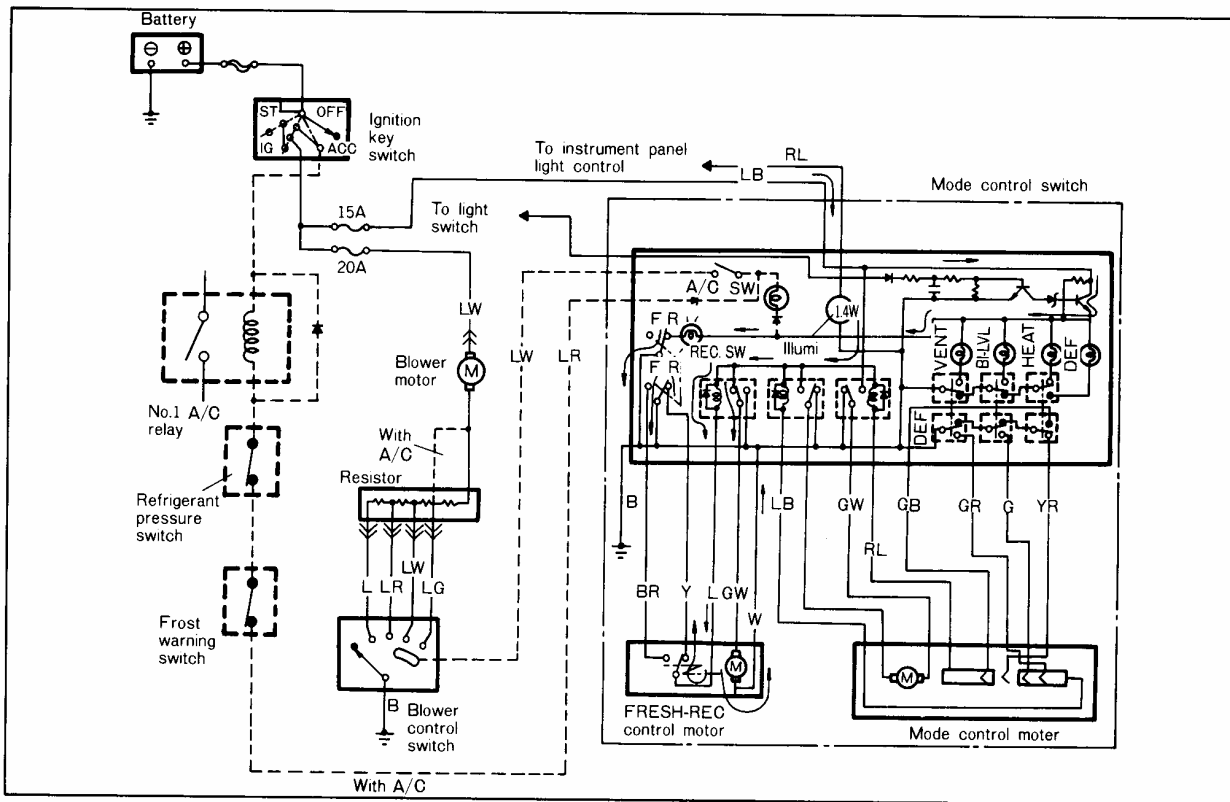

Operation when the RECIRC. switch is pressed once again (FRESH)

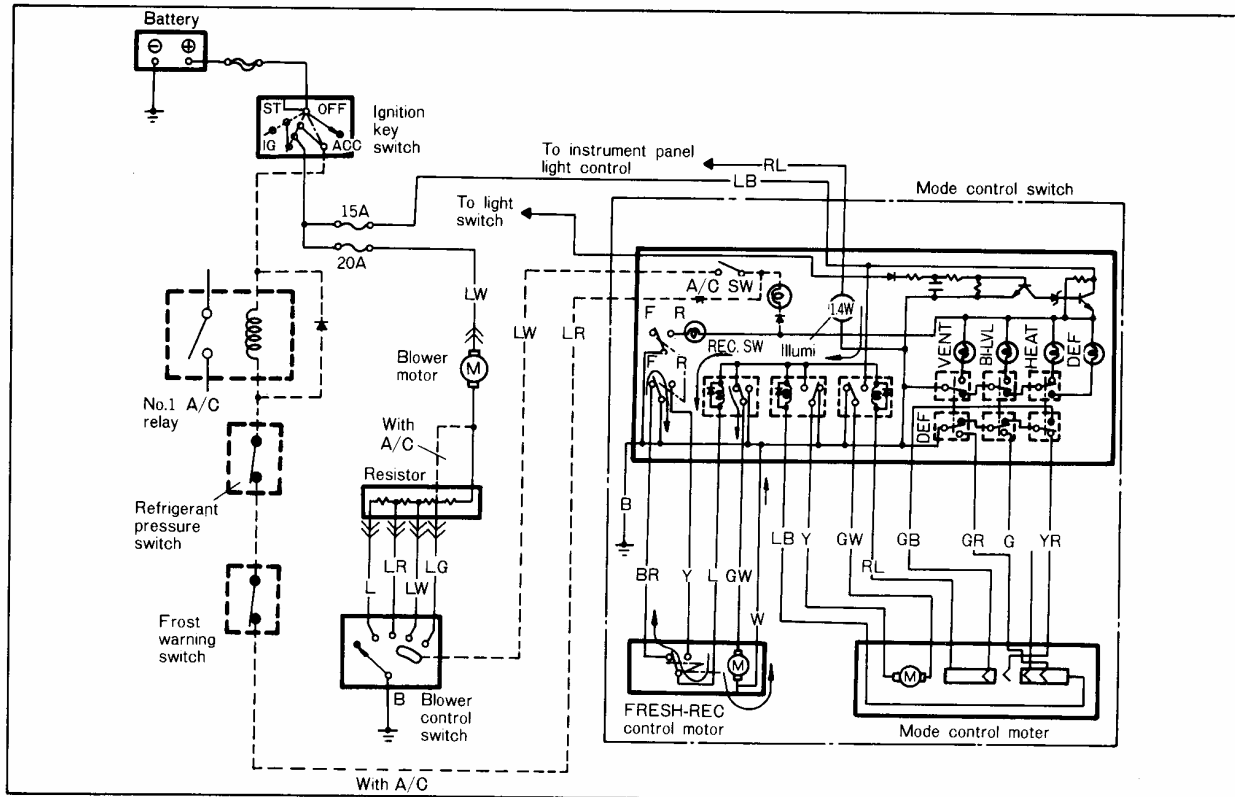

Troubleshooting Guide

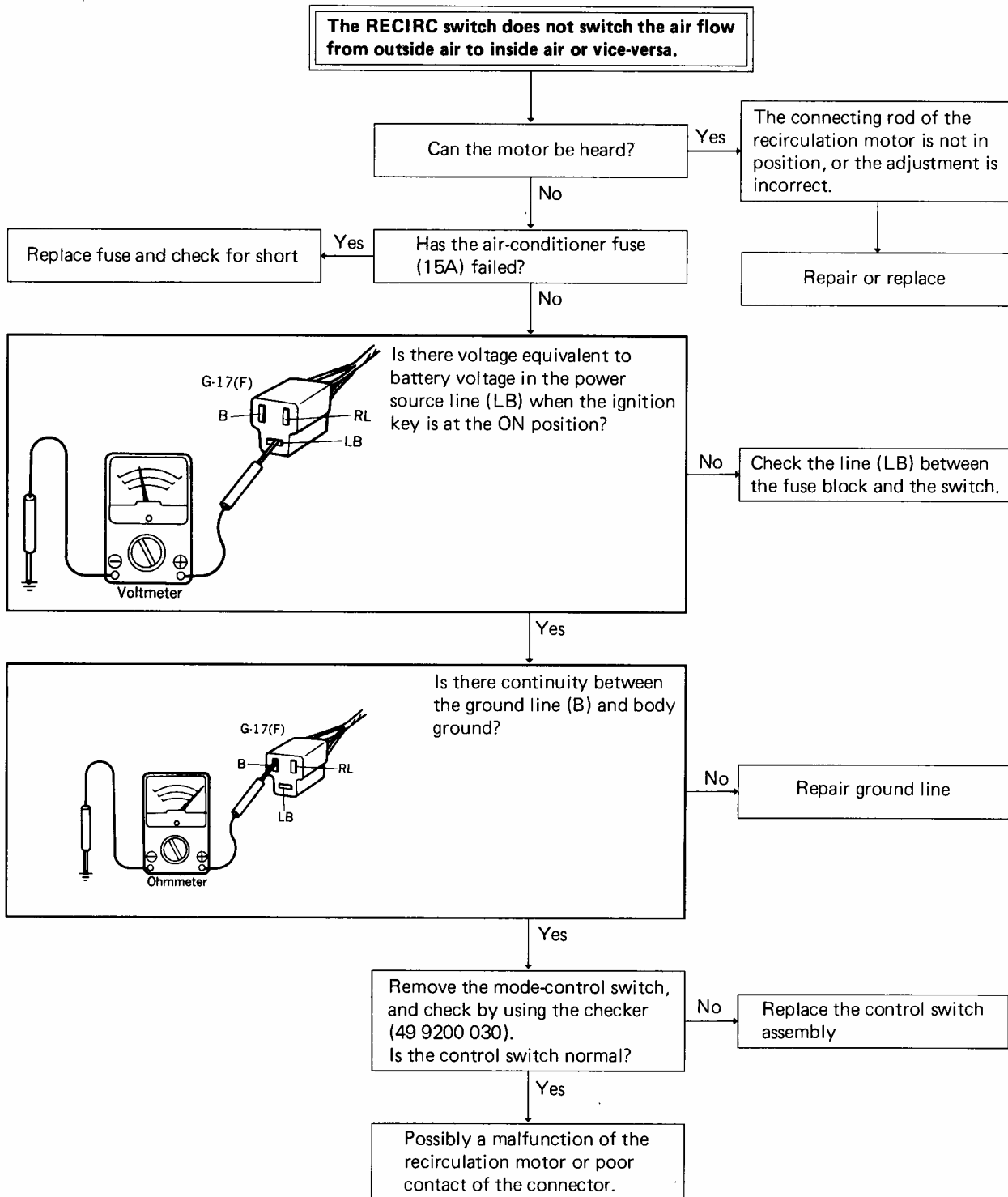

The indicator lights do not illuminate, or are too bright.

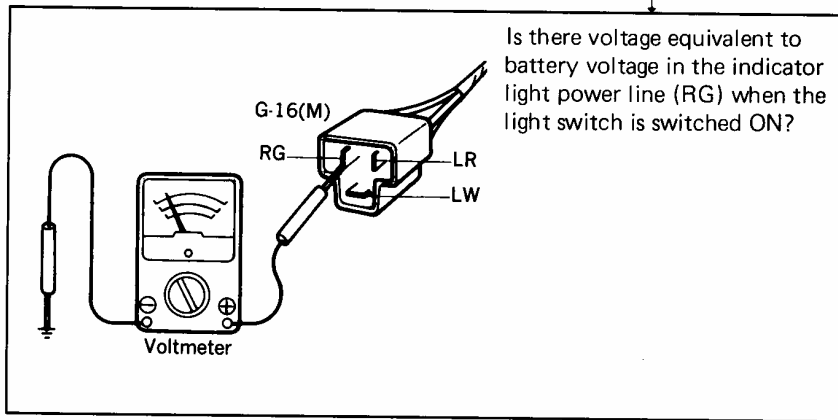

No
Check, and repair if necessary, the line (RG) leading to the light switch.

Yes

Remove the mode-control switch, and check by using the checker (49 9200 030).
Is the control switch normal?

Yes
There may be poor contact of the mode-control switch connector.

No

Replace the mode control switch assembly

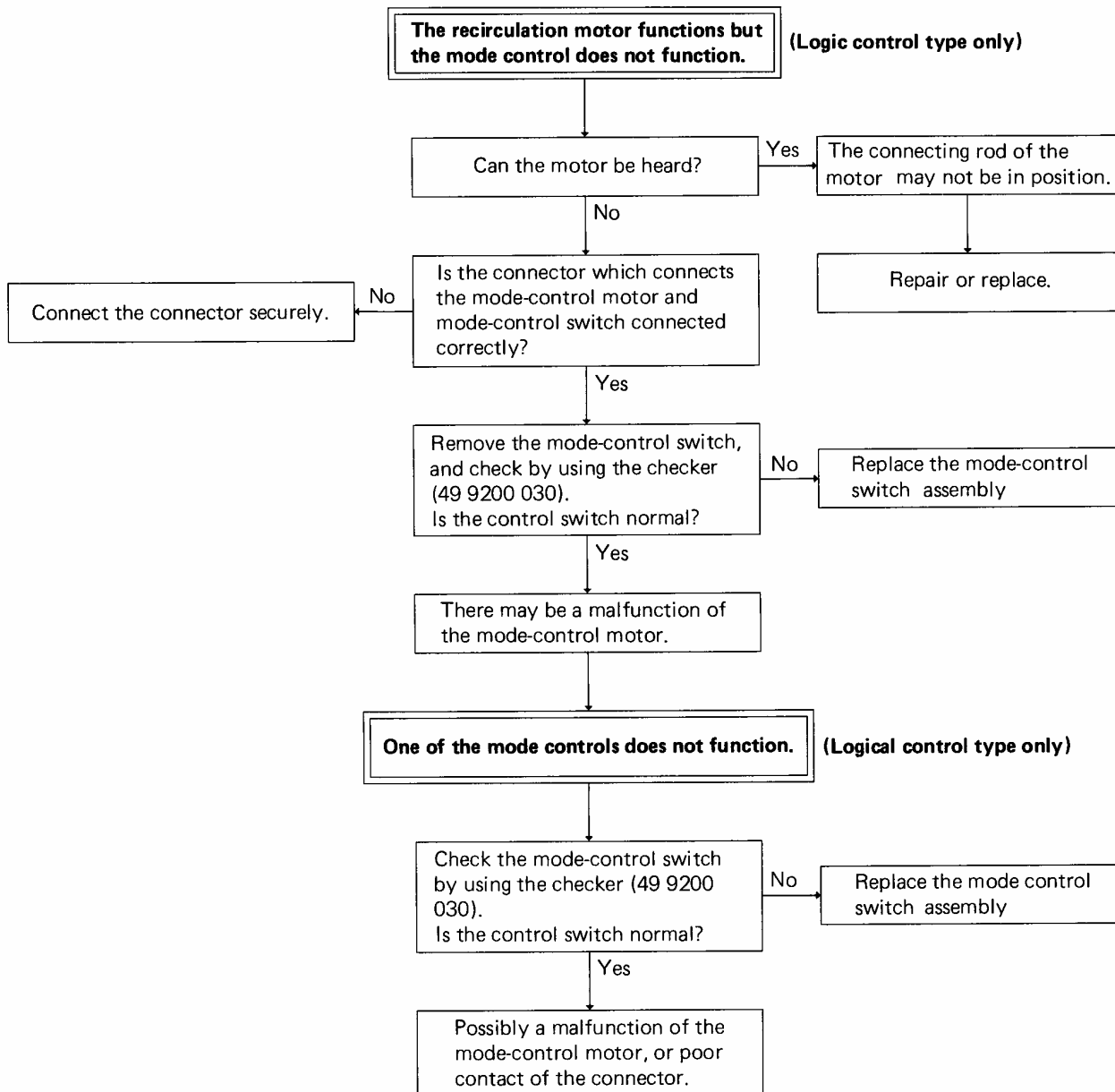

LOGICON CHECKER (49 9200 030) PARTS IDENTIFICATION

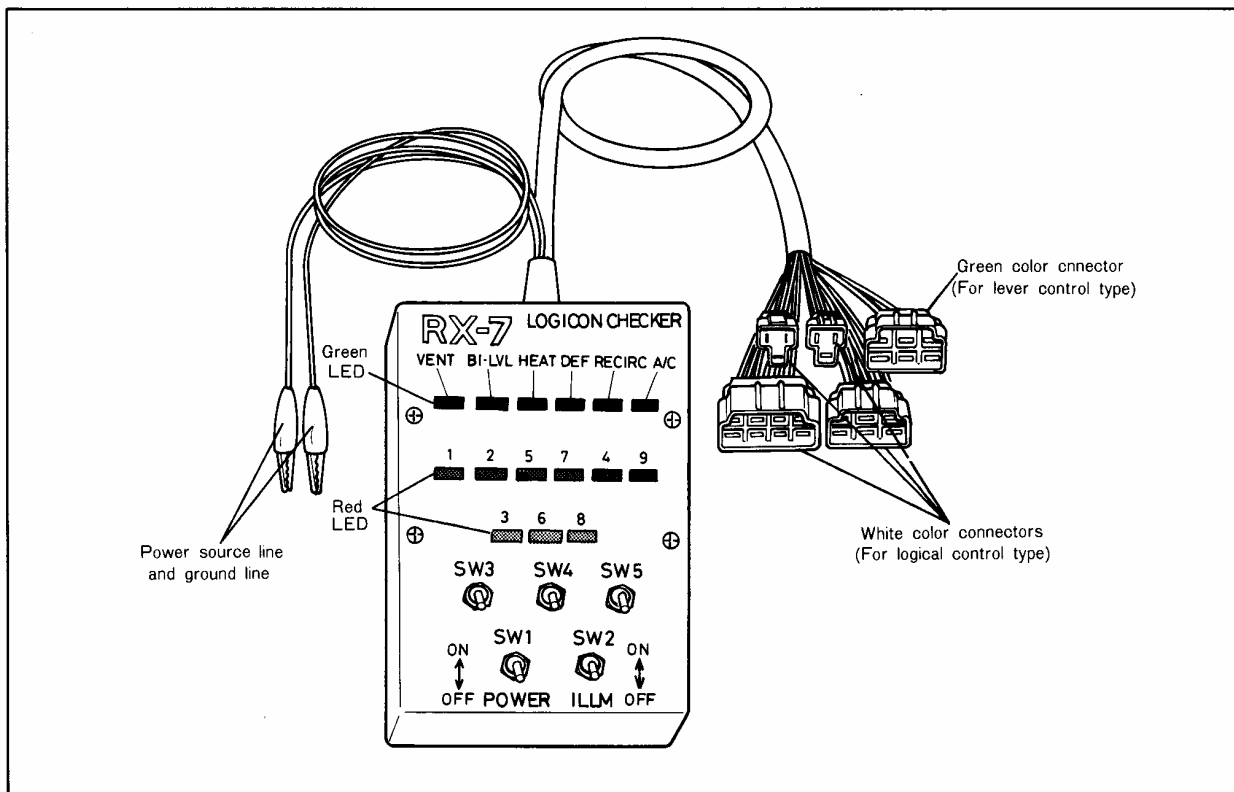
**HOW TO USE THE LOGICON CHECKER (for the logical control type)**

1. Set each switch of the checker as shown in the figure above.
2. Connect the red wire to the positive (+) terminal of the battery, and the black wire to the negative (-) terminal of the battery.
3. Securely connect each connector of the mode-control switch to the white connectors of the checker.
4. Set the power switch to the ON position.
At this time red LEDs No. 3, 4, 6 and 8, and then No. 1 LED, will illuminate. (If, however, the green RECIRC LED is illuminated, the No. 1 LED will go off.)
And, if one of the control switches is switched ON, the green LED corresponding to that switch will illuminate.
5. Press the control switches in order, and check whether or not the green LED (at the checker) corresponding to each switch respectively illuminates. If it does not illuminate, the problem is in the mode-control switch itself.

Note

- a) The red No. 1 LED will go off when, while using the checker, the RECIRC switch is switched ON, but this is a normal function.
- b) The red No. 4 LED will remain continuously illuminated during the time that the power switch is ON.

LOGICON CHECKER CONNECTIONS

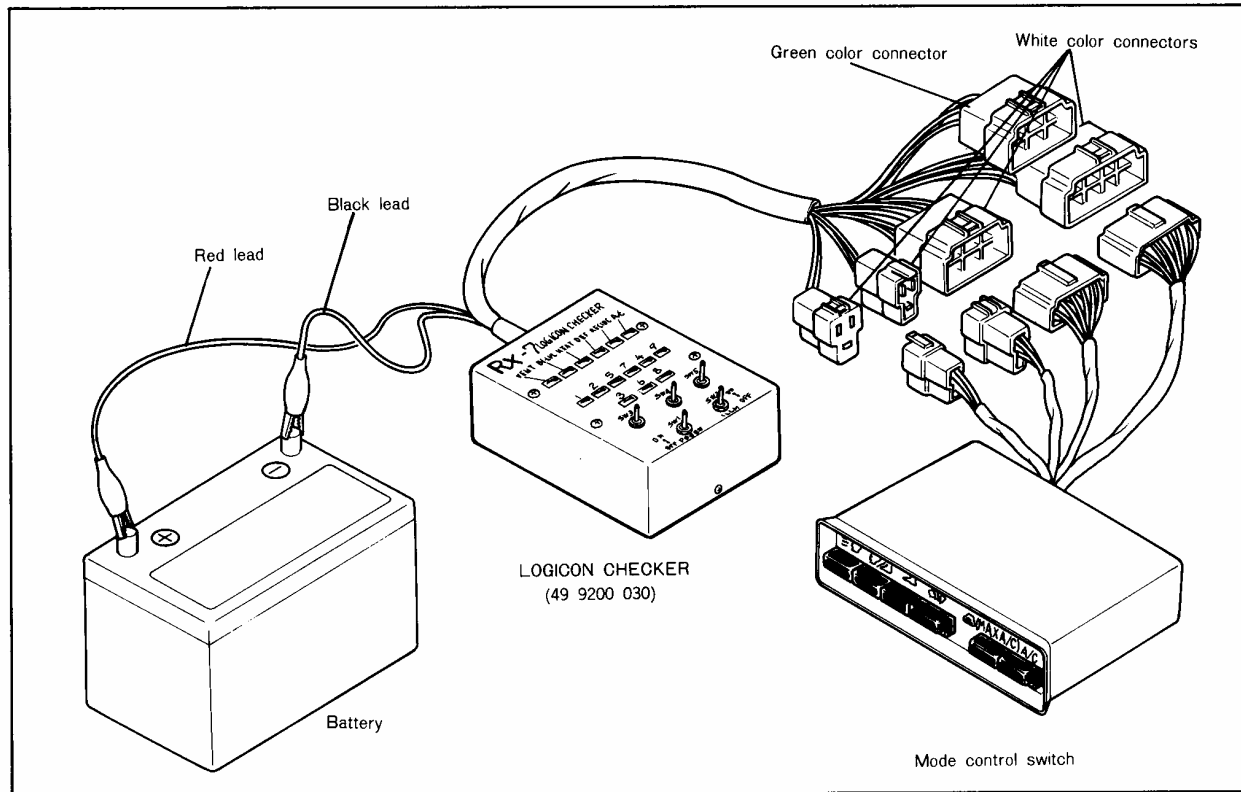

6. Operate SW3, SW4 and SW5 of the checker and make the following checks.
 - Check whether or not LED No. 2 illuminates and LED No. 3 goes off when the SW3 lever is moved to the upper position.
 - Check whether or not LED No. 5 illuminates and LED No. 7 goes off when the SW 4 lever is moved to the upper position.
 - Check whether or not LED No. 7 illuminates and LED No. 8 goes off when the SW5 lever is moved to the upper position.

If the red LEDs do not function as described above, the problem is in the mode-control switch itself.
7. Set the illumination switch to ON (by moving the lever to the upper position).
 Check to be sure that the indicator light of the control switch is dimmed at this time.
 In this condition, once again make the test described in step 5, and check to be sure that the indicator light of each mode switch is dimmed.
 If it does not, the problem is in the mode-control switch itself.

How to Use the Logicon Checker (lever control type)

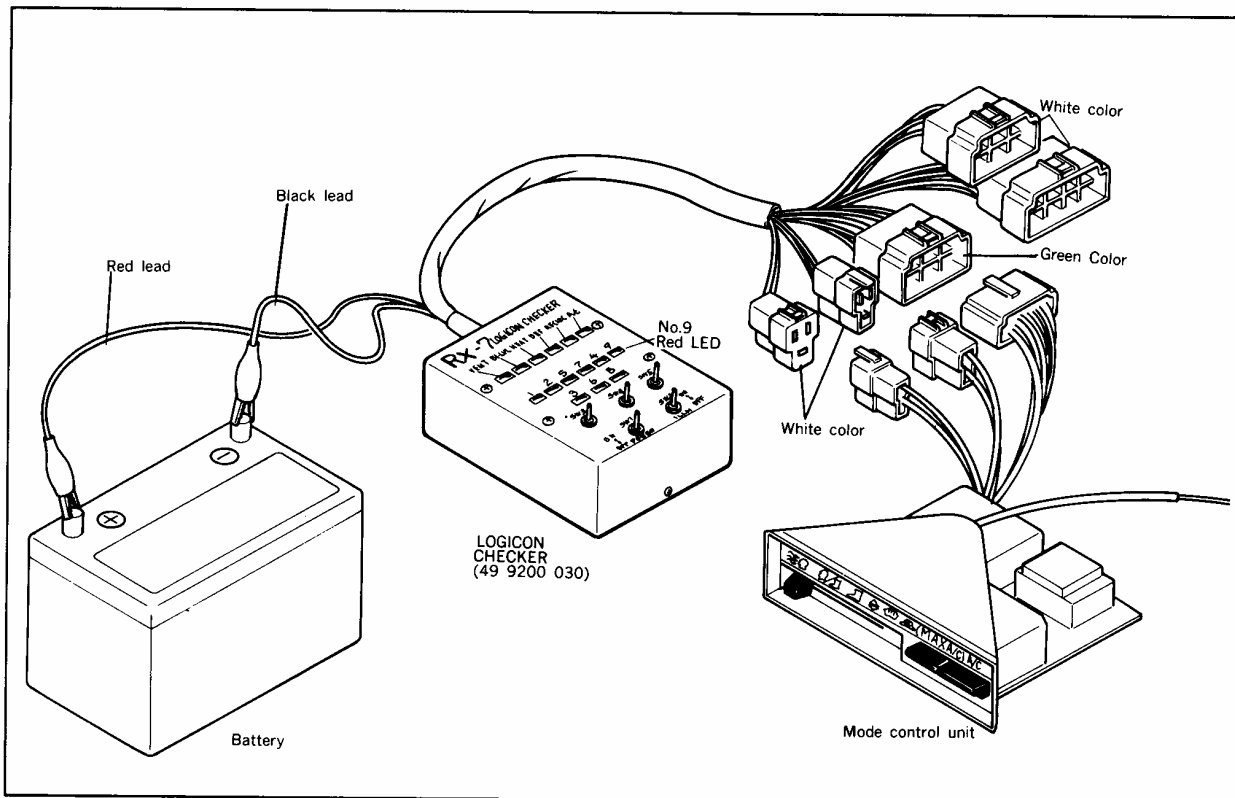

1. Set each of the checker switches as shown in the figure above.
2. Connect the red wire from the power source to the positive (+) terminal of the battery, and the black wire to the negative (-) terminal.
3. Connect the 6T connector of the mode-control switch to the 6T connector of the checker, and connect the two 3T connectors to the white 3T connectors of the checker.
4. Switch the A/C and RECIRC mode-control switches OFF. Then, switch the power switch of the checker ON.
5. When the RECIRC mode-control switch is switched ON, the No. 9 red LED of the checker will illuminate, and, at the same time, the indicator light of the switch knob will also illuminate. When the A/C switch is switched ON, the green LED (A/C) of the checker will illuminate, and, at the same time, the indicator light of the switch knob will also illuminate. (All LEDs, except the RECIRC and A/C, will be extinguished.) If the procedure is not in the order described, the problem is in the mode-control switch itself.
6. Switch ON the illumination switch. (Move the lever to the upper position.) At this time, check to be sure that the A/C switch and RECIRC switch indicator lights become dim when the VENT, BI-LEVEL and HEAT indicator lights illuminate. If they do not, the problem is in the mode-control switch itself.