

1985 RX-7 & 1984 B2000/B2200

SUBJECT Roller Bearing & Main Shaft.

DESCRIPTION

To further improve the reliability of the transmission, the following modifications have been made.

1. The roller bearing has been enlarged and the recess in the main drive gear has been enlarged to accept the new roller bearing.

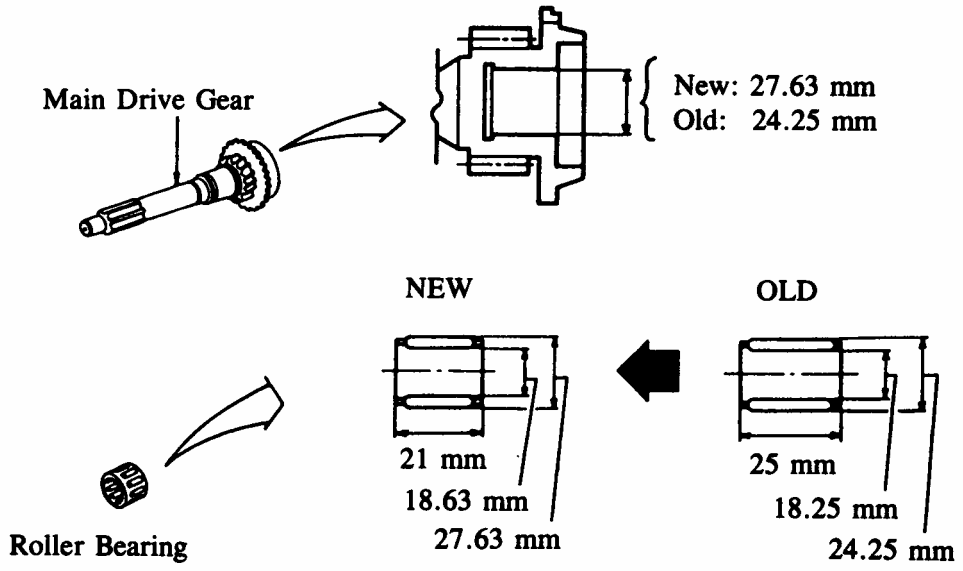

2. The method of retaining the bearing on the main shaft has been changed from clips to thrust washers with retaining rings.

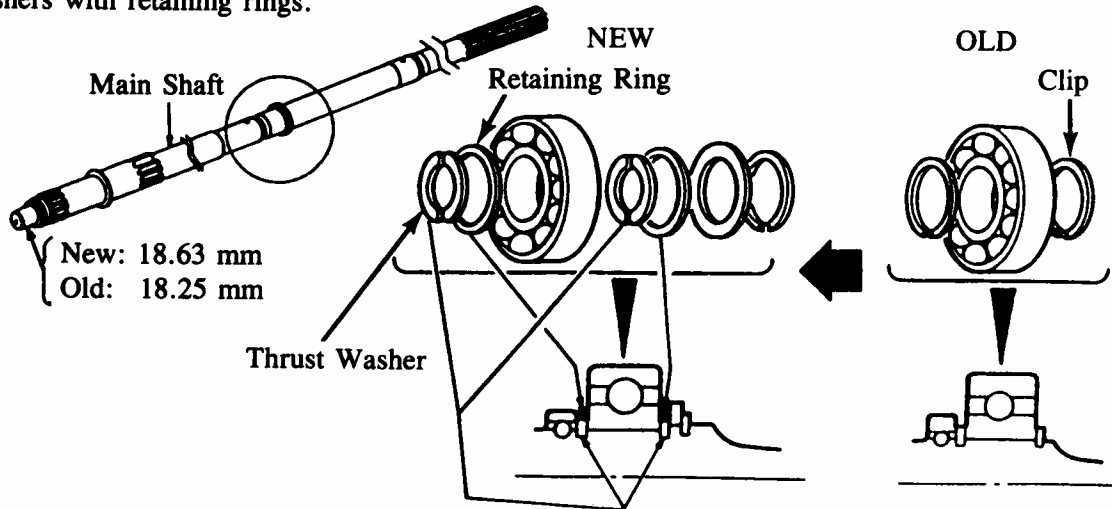

### VIN OF PRODUCTION CHANGE

RX-7	12A:	JM1FB331 F0876904	December, 1984
	13B:	JM1FB332 F0876904	December, 1984
B2000	Short Bed:	JM2UC121 E0919987	December, 1984
	Long Bed:	JM2UC221 E0844354	December, 1984
B2200	Short Bed:	JM2UD121 E0801687	December, 1984
	Long Bed:	JM2UD221 E0803537	December, 1984

### PARTS INFORMATION

RX-7

PART NUMBER		DESCRIPTION	APPLIED MODEL/ DESCRIPTION	INTERCHANGEABILITY
NEW	OLD			
M506 17 201A	M506 17 201	Main Drive Gear	(12A)	NO
M502 17 221A	M502 17 221	Main Shaft	(12A)	NO
M506 17 201A	M506 17 201	Main Drive Gear	(13B)	NO
M505 17 221A	M505 17 221	Main Shaft	(13B)	NO
M501 17 210	0249 17 210B	Roller Bearing	-	NO
0839 17 305B	-	Retaining Ring	-	-
0884 17 632B	0884 17 632A	Thrust Washer	(T=6.2)	NO
0884 17 633B	0884 17 633A	Thrust Washer	(T=6.4)	NO
0884 17 634B	0884 17 634A	Thrust Washer	(T=6.5)	NO
0884 17 635B	0884 17 635A	Thrust Washer	(T=6.6)	NO
M501 17 651	0862 17 641A	Thrust Washer	(T=3.0)	NO

RX-7

PART NUMBER		DESCRIPTION	APPLIED MODEL/ DESCRIPTION	INTERCHANGEABILITY
NEW	OLD			
M501 17 653	0862 17 642A	Thrust Washer	(T=3.1)	NO
M501 17 654	0862 17 643A	Thrust Washer	(T=3.2)	NO
M501 17 655	0862 17 644A	Thrust Washer	(T=2.9)	NO
M501 17 652	-	Ring	-	-
9995 52 640	-	Adjust Washer	-	-